

Big bin-filler - BGV-series



BGV-1-2 - 2x



BGV-1-1 - 2x



BGV-1-2 with weighing unit



BGV-1-1—Mobile



BGV-1-1

- Grootkistenvuller
- Big bin-filler
- Großkistenfüller
- Napelniacz skrzyniopalet

Capacity:
 5-9 bins per hour



- Geschikt voor verschillende kistmaten.
- Door toepassing van vulband uit één stuk geen extra overgang.
- Compacte bouwwijze.
- Roterende vulschijf voor appels en peren met aflegslab met anti-knel voorziening.



- Suitable for different bin sizes.
- By use of a filling conveyor out of one piece no extra transfer required.
- Compact machine construction.
- Rotating filling disk for apples and pears with a flap with pinch protection device.



- Verschiedene Kistmaße.
- Wegen Fingerförderband aus einem Stück kein extra Übergang.
- Kompakte Bauweise.
- Rotierendes Abfullgerät für Äpfel und Birnen mit Gummischutz and Anti-Stecken Schutz.



- Przystosowany do różnych rozmiarów skrzyniopalet
- Podajnik palcowy zapewnia delikatny załadunek owoców
- Zwarta i prosta konstrukcja
- Obrotowy dysk zapewnia równomierne napełnienie skrzynio palety.
- Opcjonalnie – system ważenia skrzyniopalet.

Dimension views - BGV bin-fillers

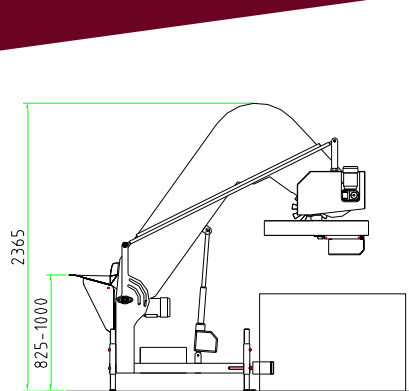

Sideview BGV-series

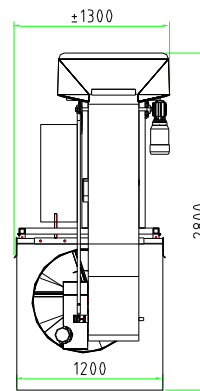

BGV-1-1

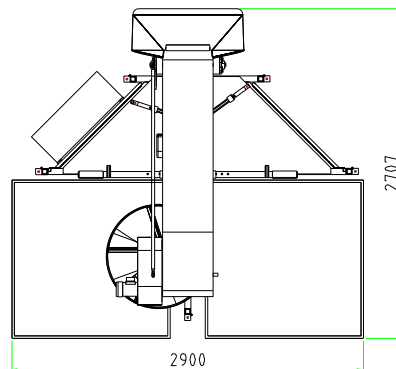

BGV-1-2

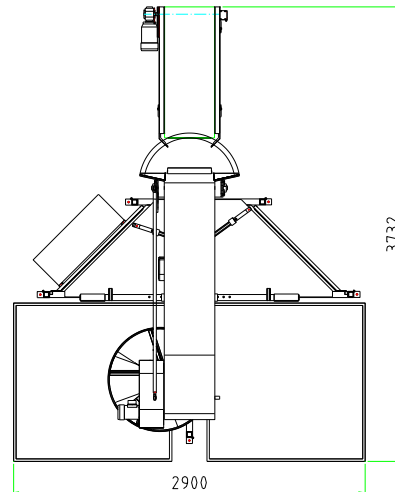

BGV-1-2 - HC



BURG MACHINEFABRIEK BV

Weihhoek 11 • 4416 PX • Kruijningen • Nederland • info@burg-machinefabriek.nl
Telefoon +31 (0) 113 - 50 13 73 • Fax +31 (0) 113 - 50 21 08

innovating the fruit and agriculture industry

www.burg-machinefabriek.nl

DEALER / VERTRETUNG: