

Waterunloader apples - AL-E



- Waterlediger appels
- Waterunloader apples
- Wasserentleerer Äpfel
- Rozładunek wodny do jabłek





- Modulaire, compacte bouwwijze.
- Vruchtvriendelijke overgangen.
- Diverse capaciteiten leverbaar.
- Diverse kistmaten mogelijk.
- Continu aanvoer van product.
- Reinigende en poetsende werking.
- Verschillende droogsystemen leverbaar.
- Plaatwerk en droger in RVS uitgevoerd.
- Diverse opstellingen mogelijk.

- Modular and compact machine construction.
- Fruit-friendly transfers.
- Range of capacities.
- Suitable for different bin sizes.
- Continuous product flow.
- Cleaning and brushing your products.
- Various types of drying systems.
- Tanks, channels and drying system in stainless steel.
- Several lay-out configurations possible.

- Modulare und kompakte Bauweise.
- Fruchtschonende Übergänge.
- Verschiedene Kapazitäten lieferbar.
- Verschiedene Kistenmaße möglich.
- Kontinuierliche Zufuhr der Äpfel.
- Reinigen und Putzen der Äpfel.
- Verschiedene Trocknersysteme lieferbar.
- Becken, Kanäle und Trockner im Edelstahl.
- Verschiedene Aufstellungsmöglichkeiten.

- Nie uszkadza owoców.
- Przystosowany do różnych rozmiarów skrzyniopalet.
- Ciągły przepływ jabłek.
- Mycie i czyszczenie jabłek.
- Różne typy systemów osuszania jabłek.
- Na życzenie części ze stali nierdzewnej.
- Zwarta i prosta konstrukcja.
- Konfiguracja maszyny na życzenie klienta.

Dimension view - AL-E - Basic version

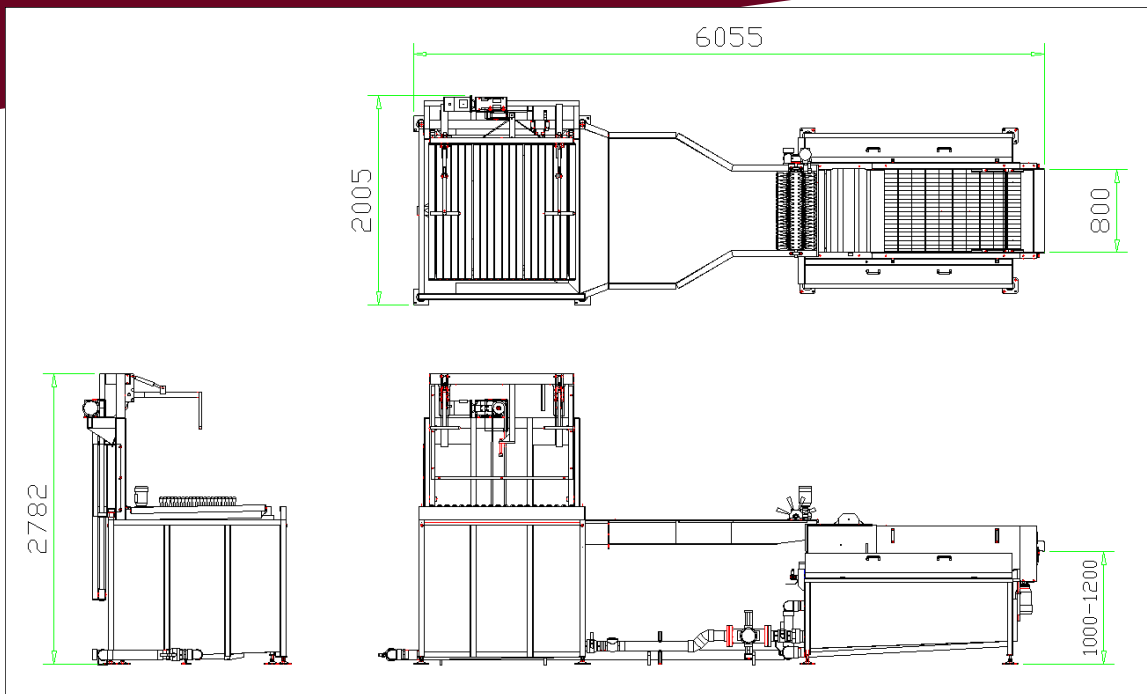

AL-E BIO - Hot water treatment



BURG MACHINEFABRIEK BV

Weihoek 11 • 4416 PX • Kruijningen • Nederland • info@burg-machinefabriek.nl
Telefoon +31 (0) 113 - 50 13 73 • Fax +31 (0) 113 - 50 21 08

innovating the fruit and agriculture industry

www.burg-machinefabriek.nl

DEALER / VERTRETUNG: